

ISTRUZIONI PER L'INSTALLAZIONE  
INSTALLATION INSTRUCTIONS  
INSTALLATIONSANLEITUNG  
INSTRUCTIONS POUR L'INSTALLATION  
INSTRUCCIONES PARA LA INSTALACIÓN

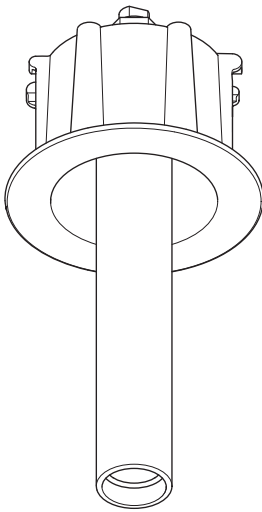

**MENO SPOT**  
Vcc: max 500ma

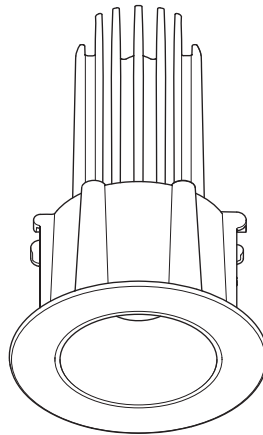

**MENO PRO**  
Vcc: max 700ma

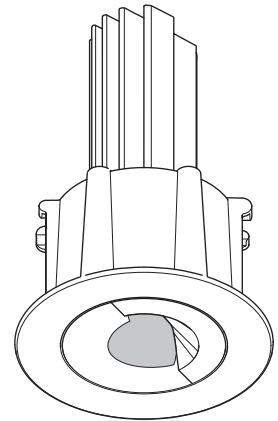

**MENO WALLWASHER**  
Vcc: max 700ma

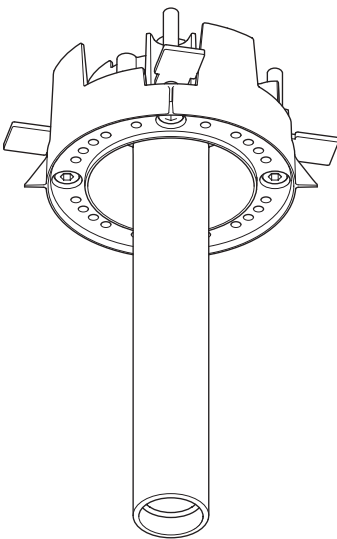

**MENO SPOT TRIMLESS**  
Vcc: max 500ma

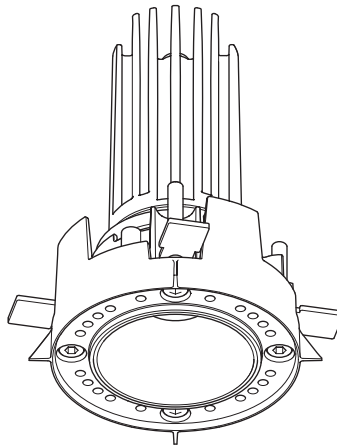

**MENO PRO TRIMLESS**  
Vcc: max 700ma

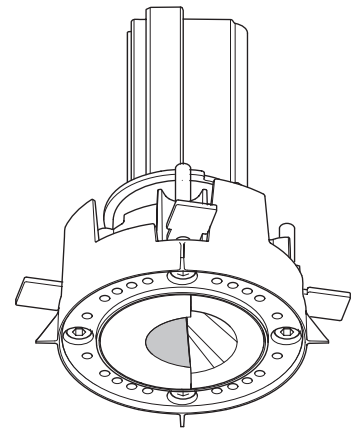

**MENO WALLWASHER  
TRIMLESS**  
Vcc: max 700ma

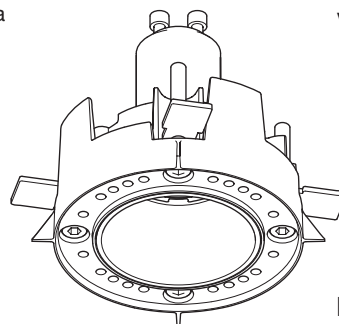

**MENO GU10  
TRIMLESS**  
4W max

# Meno

CE IP20

# CINI & NILS

### Caratteristiche di sicurezza

Apparecchio a LED costruito secondo le norme europee di sicurezza EN60598-1.

La sicurezza è garantita solo se l'apparecchio viene installato e usato in modo appropriato in base alle relative istruzioni.

Queste istruzioni devono essere conservate con cura per ogni ulteriore consultazione.

### Avvertenze

■ Funzionamento con corrente costante.

In caso di utilizzo di più prodotti, i prodotti vengono collegati in serie.

Alimentare solo dopo che tutti i faretti sono collegati.

Lunghezze dei cavi consigliate ≤30m.

Rispettare le polarità: + rosso - nero.

Utilizzare alimentatori tipo SELV o equivalenti conformi alla norma EN 61347-2-13.

■ Il corretto funzionamento e la durata dei componenti elettronici e dei led è garantito solo in presenza di:

- impianto elettrico certificato ed esente da picchi di tensione.

- cablaggi e dispositivi (interruttori, prese, dimmer, eccetera) in perfetto stato.

■ Apparecchio da installare con tensione disattivata dal quadro generale.

Prima di qualunque intervento togliere tensione all'apparecchio: rischio di scossa elettrica.

■ Apparecchio adatto solo per uso in interni.

■ Sorgente luminosa GU10 mr11 inclusa e sostituibile dall'utilizzatore finale. In caso di sostituzione utilizzare sorgente luminosa con caratteristiche simili.

■ Questo prodotto contiene una sorgente luminosa di classe di efficienza energetica E.

■ L'apparecchio non deve, in alcuna circostanza, essere coperto con materiale isolante o similari.

■ Le operazioni di pulizia vanno eseguite con un panno asciutto, non utilizzare alcun tipo di detergente.

■ Utilizzare solo parti di ricambio originali.

■ È assolutamente vietato smontare o manomettere l'apparecchio, nel caso in cui si verificassero situazioni anomale spegnere immediatamente e contattare il rivenditore o il servizio post vendita Cini&Nils.

■ Cini&Nils declina ogni responsabilità derivante da manomissione e/o smontaggio dell'apparecchio eseguito da personale non autorizzato.

### Dimmerazione

■ Apparecchio Dimmerabile con Driver Push/1-10 e Dali (non incluso).

### Safety features

LED luminaire, constructed in compliance with the European safety standard EN60598-1.

Safety is guaranteed only if the fitting is used correctly, in accordance with the relevant instructions.

Keep these instructions carefully for future reference.

### Warning

■ Constant current operation.

If several products are used, products are connected in series.

Power up only after all the spotlights have been connected.

Recommended cable length ≤30m.

Respect the polarity: + red - black.

Use only SELV type electronic power supplies or similar compliant with the EN 61347-2-13 standard.

■ The electric components and LEDs are guaranteed to function correctly only when:

- the wiring system is certified and free of voltage surges.

- the wiring and devices (switches, sockets, dimmers etc.) are in perfect condition.

■ Always cut the power from the mains before any installation or other work.

Cut off the power to the fitting before doing any work: electric shock hazard.

■ This fitting is suitable for indoor installation only.

■ Light source GU10 mr11 included and replaceable by the end user. In case of replacement, use a light source with similar characteristics.

■ This product contains a Class E energy efficiency light source.

■ The light fitting must never, under any circumstances, be covered with insulating or similar materials.

■ Clean with a dry cloth, do not use any detergent.

■ Use only original spare parts.

■ Never dismantle or tamper with the device under any circumstances. In case of anomaly, switch it off immediately and contact your retailer or the Cini&Nils after-sales service.

■ Cini&Nils cannot accept responsibility pursuant to any tampering with the device and/or dismantling it if this is undertaken by anyone without the necessary authorisation.

### Dimming

■ Light fitting can be dimmed with Driver Push/1-10 and Dali (not included).

### Sicherheitsmerkmale

LED-Leuchte ist im Einklang mit der europäischen Sicherheitsnorm EN60598-1.

Die Betriebssicherheit der Leuchte ist jedoch nur bei sachgerechtem Einbau und Gebrauch gemäß Anweisungen gewährleistet.

Bewahren Sie alle Anweisungen zur späteren Einsichtnahme sorgfältig auf.

### Warnhinweise

■ Betrieb mit konstantem Strom.

Im Fall einer Verwendung mehrerer Produkte werden die Produkte in Serie angeschlossen.

Erst mit Strom versorge, wenn alle Scheinwerfer angeschlossen sind.

Empfohlene Kabellänge ≤30m.

Die Polarität beachten: + Rot - Schwarz.

Verwenden Sie SELV-Netzteile oder gleichwertige, die der Norm EN 61347-2-13 entsprechen.

■ Die sachgerechte Funktion und Lebensdauer der elektronischen Bauelemente und Leuchtdioden ist nur unter folgenden Bedingungen gewährleistet:

- zertifizierte Elektroanlage ohne Spannungsspitzen.

- Verdrahtung und Anlagenteile (Schalter, Steckdosen, Dimmer usw.) in einwandfreiem Zustand.

■ Vor der Installation und vor jeglichen anderen Arbeiten stets die Stromzufuhr beim Sicherungskasten unterbrechen.

Vor jeglichen Arbeiten an den Leuchten ist stets die Stromzufuhr zu unterbrechen: Gefahr eines elektrischen Schlags.

■ Leuchten nur zum Gebrauch in Innenräumen geeignet.

■ Lichtquelle GU10 mr11 enthalten und vom Endverbraucher austauschbar. Verwenden Sie im Falle eines Austauschs eine Lichtquelle mit ähnlichen Eigenschaften.

■ Dieses Produkt enthält eine Lichtquelle der Energieeffizienzklasse E.

■ Das Gerät darf nie mit Isoliermaterial oder ähnlichem bedeckt werden.

■ Mit einem trockenen Tuch reinigen. Keine Reinigungsmittel verwenden.

■ Verwenden Sie nur Original-Ersatzteile.

■ Die Leuchte darf unter keinen Umständen auseinandergebaut oder verändert werden; bei ungewöhnlichem Verhalten abschalten und den Händler oder den Cini&Nils Kundendienst kontaktieren.

■ Cini&Nils schließt bei Eingriffen durch Unbefugte und/oder Änderungen an der Leuchte jede Haftung aus. Die Leuchte von Wärmequellen fernhalten.

### Dimmen

■ Dimmbare Leuchte mit Driver Push/1-10 und Dali (nicht mitgeliefert).

### Caractéristiques de sécurité

Appareil à LED, construit conformément aux normes de sécurité européennes EN60598-1.

La sécurité est garantie seulement si l'appareil est installé et utilisé de façon appropriée conformément aux instructions.

Conservé avec soin ces instructions pour toute consultation ultérieure.

### Avertissements

■ Fonctionnement à courant constant.

Si se utilizan varios productos, estos se conectan en serie.

Alimenter seulement après que tous les spots aient été branchés.

Longueurs de câbles conseillées ≤30m.

Respecter la polarité: + rouge - noir.

Utiliser des alimentateurs de type SELV ou équivalent conformes à la norme EN 61347-2-13.

■ Le fonctionnement correct et la durée des composants électroniques et des led est garanti seulement en présence de:

- une installation électrique certifiée et exempte de pics de tension.

- des câblages et des dispositifs, (interrupteurs, prises, dimmers, etcétera), en parfait état.

■ Avant toute installation et intervention, couper le courant au tableau général.

Couper le courant avant toute intervention sur l'appareil: risque de choc électrique.

■ Appareils aptes pour un usage en intérieurs seulement.

■ Source lumineuse GU10 mr11 incluse et remplaçable par l'utilisateur final. En cas de remplacement, utilisez une source lumineuse aux caractéristiques similaires.

■ Ce produit contient une source lumineuse de classe d'efficacité énergétique E.

■ L'appareil ne doit en aucun cas être recouvert par du matériel isolant ou similaire.

■ Il faut exécuter les opérations de nettoyage avec un chiffon sec; n'utiliser pas aucun détergent.

■ Utilisez uniquement des pièces de rechange d'origine.

■ L'appareil ne doit absolument pas être démonté, ni modifié. En cas d'anomalie, éteignez-le immédiatement et contactez le revendeur ou le service après-vente de Cini&Nils.

■ Cini&Nils décline toute responsabilité en cas de manipulation et/ou de démontage de l'appareil effectué par du personnel non autorisé.

### Dimmeration

■ Appareil gradable avec Driver Push/1-10 et Dali (non inclus).

### Características de seguridad

Aparato de LED, fabricado según las normas europeas de seguridad EN60598-1.

La seguridad se garantiza sólo si el aparato se instala y se usa de manera apropiada siguiendo las instrucciones correspondientes.

Conservar cuidadosamente estas instrucciones para futuras consultas.

### Advertencias

■ Funcionamiento con corriente constante.

Espaçadores em poliuretano expandido para aplicação em parede.

Conectar a la red eléctrica solo cuando todos los focos estén conectados.

Longitud aconsejada e los cables ≤30m.

Respete la polaridad: + rojo - negro.

Utilizar alimentadores del tipo SELV o equivalentes que cumplan con la norma EN 61347-2-13.

■ El correcto funcionamiento y la duración de los componentes electrónicos y de los leds están garantizados únicamente si:

- la instalación eléctrica está certificada y no está sujeta a picos de tensión.

- el cableado y los dispositivos (interruptores, tomas, dimmers, etc.) están en perfecto estado.

■ Antes de realizar cualquier operación cortar la alimentación eléctrica del aparato.

Antes de realizar cualquier operación cortar la alimentación eléctrica del aparato: riesgo de descarga eléctrica.

■ Aparatos indicados exclusivamente para uso en interiores.

■ Fuente de luz GU10 mr11 incluida y reemplazable por el consumidor final. En caso de sustitución, utilice una fuente de luz de características similares.

■ Este producto contiene una fuente de luz de clase de eficiencia energética E.

■ El aparato no debe, en ningún caso, cubrirse con material aislante o similares.

■ Las operaciones de limpieza se deben realizar con un paño seco, sin usar ningún tipo de detergente.

■ Use solo repuestos originales.

■ Está absolutamente prohibido desmontar o manipular el aparato. Si se verificaran situaciones anómalas, apagarlo inmediatamente y contactar con el revendedor o con el servicio postventa de Cini&Nils.

■ Cini&Nils declina toda responsabilidad derivada de la manipulación y/o desmontaje del aparato realizado por personal no autorizado.

### Regulación

■ Aparato Atenuable con Driver Push/1-10 y Dali (no incluido).

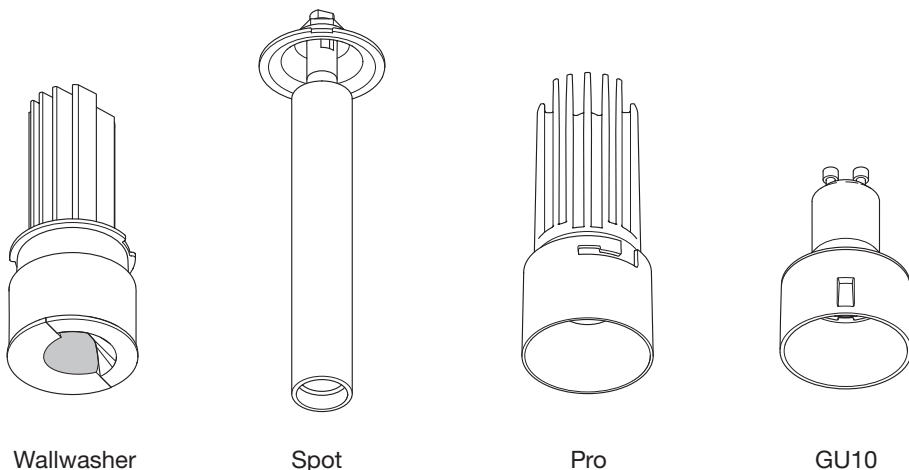

**1x**  
 corpo della lampada  
 body of the lamp  
 Leuchtenkörper  
 corps de la lampe  
 cuerpo de la lámpara

Wallwasher

Spot

Pro

GU10

PRO

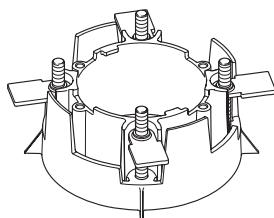

SPOT - GU10

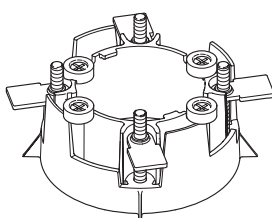

WALLWASHER

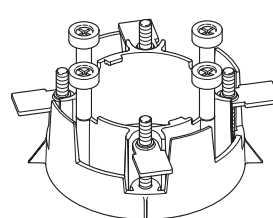

PRO

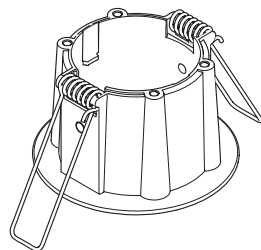

SPOT - WALLWASHER

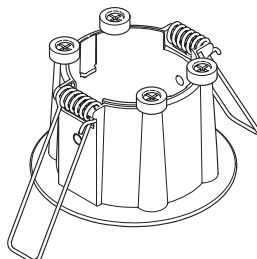

**1x**  
 corpo della lampada  
 body of the lamp  
 Leuchtenkörper  
 corps de la lampe  
 cuerpo de la lámpara

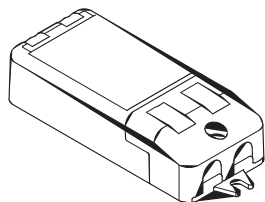

**1x**  
 alimentatore  
 power supply unit  
 Netzteil  
 adaptateur  
 alimentador

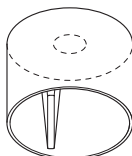

**1x**  
 tappo  
 cap  
 deckel  
 bouchon  
 tapón

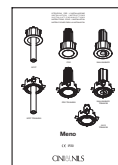

istruzioni  
 instructions  
 Montageanleitung  
 instructions  
 instrucciones

SOLO VERSIONE GU10 - GU10 VERSION ONLY - NUR AUSFÜHRUNG GU10 - VERSION GU10 UNIQUEMENT - SÓLO VERSIÓN GU10

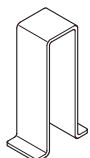

**1x**  
 estrattore lampada GU10  
 GU10 luminary extractor  
 Extraktionswerkzeug für Lampe GU10  
 extracteur de lampe GU10  
 extractor de lámpara GU10

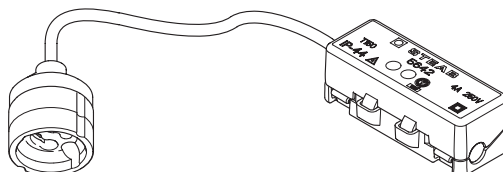

**1x**  
 portalampada GU10  
 GU10 luminary socket  
 Lampenhalterung GU10  
 douille GU10  
 portalámpara GU10

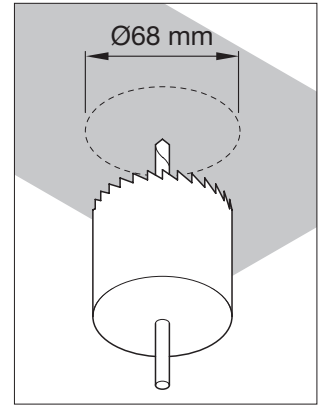
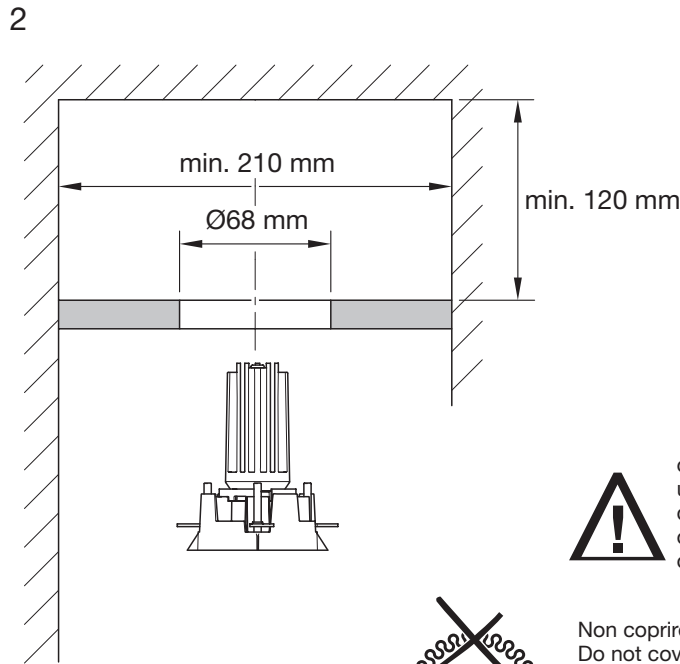

obbligo usare fresa a tazza  
 use of hole cutter is mandatory  
 das Verwenden einer Lochfräse ist erforderlich  
 obligation d'utiliser une scie-cloche  
 obligación de utilizar broca de corona

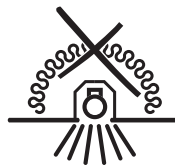

Non coprire l'apparecchio con materiale termoisolante.  
 Do not cover the fixture with heat insulating material.  
 Decken Sie das Gerät nicht mit Wärmeisoliermaterial ab.  
 Ne pas couvrir l'appareil avec un matériau d'isolation.  
 No cubra el aparato con material de aislamiento térmico.

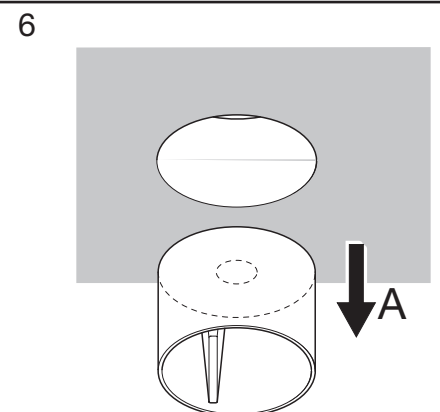
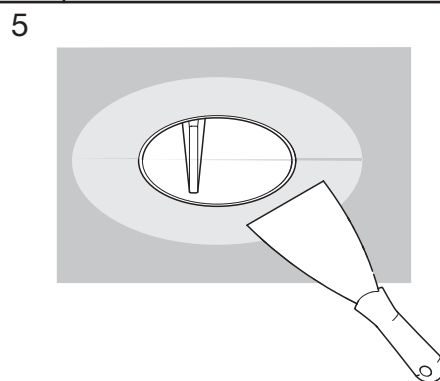
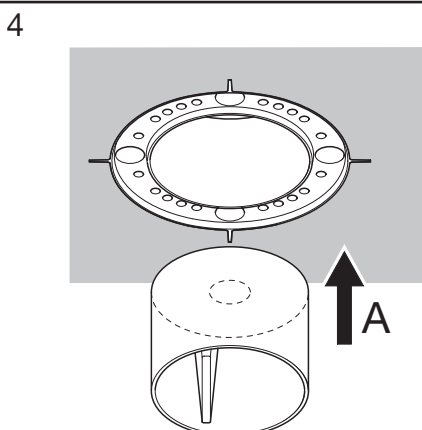
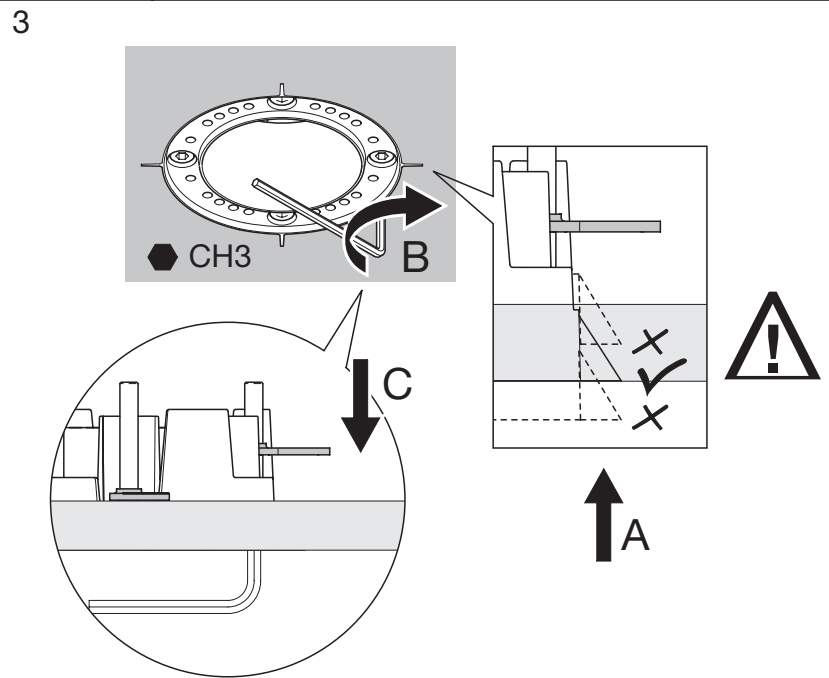
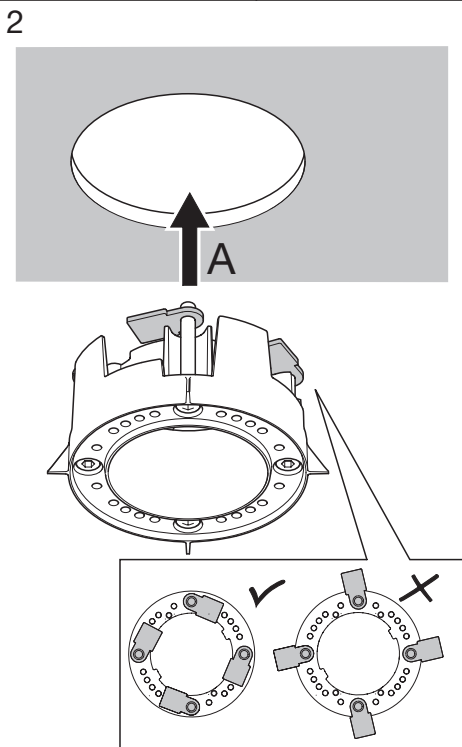

1

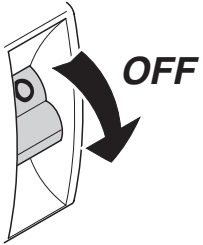

2

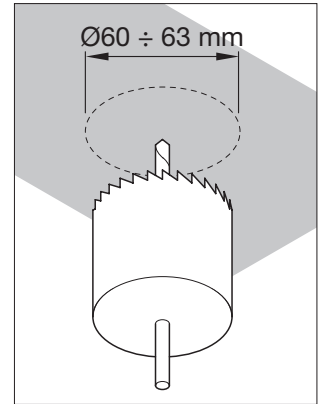
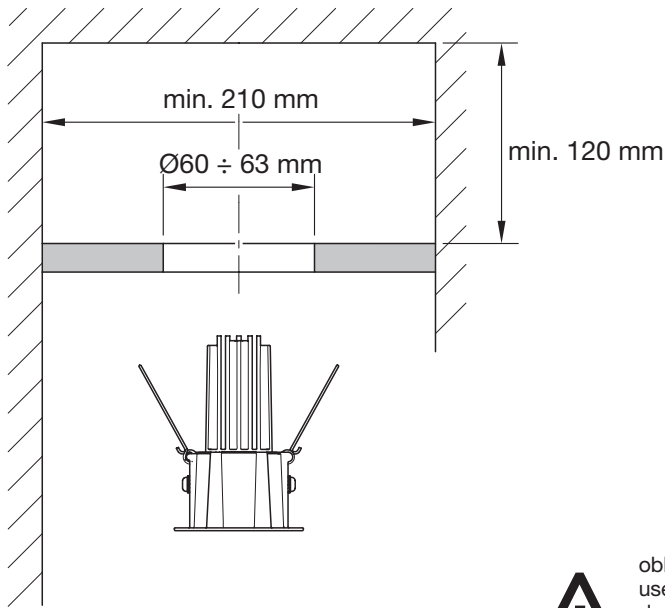

obbligo usare fresa a tazza  
 use of hole cutter is mandatory  
 das Verwenden einer Lochfräse ist erforderlich  
 obligation d'utiliser une scie-cloche  
 obligación de utilizar broca de corona

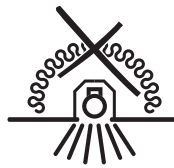

Non coprire l'apparecchio con materiale termoisolante.  
 Do not cover the fixture with heat insulating material.  
 Decken Sie das Gerät nicht mit Wärmeisoliermaterial ab.  
 Ne pas couvrir l'appareil avec un matériau d'isolation.  
 No cubra el aparato con material de aislamiento térmico.

3

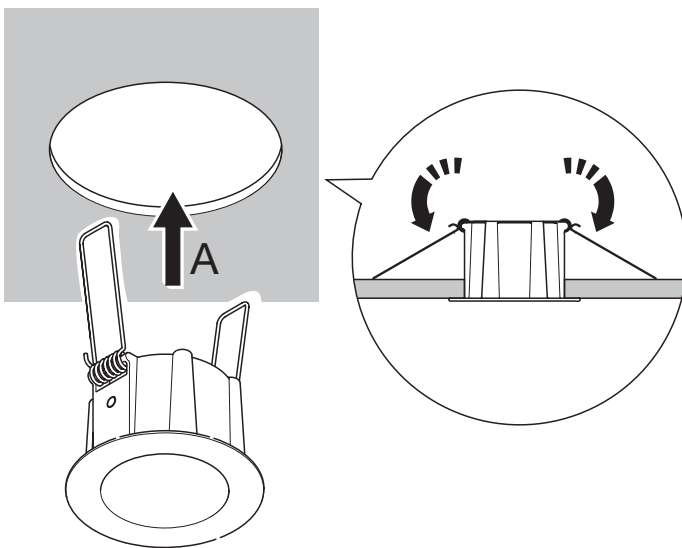

4

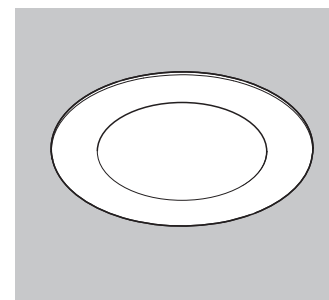

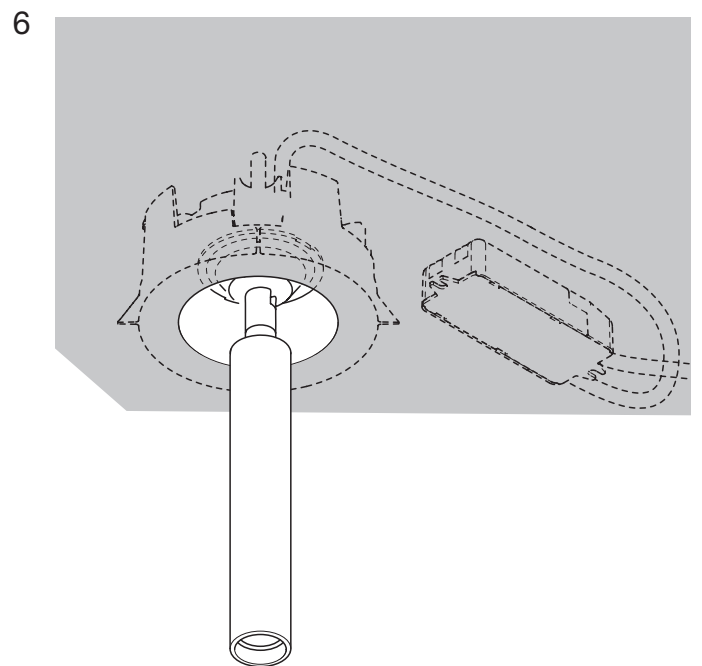
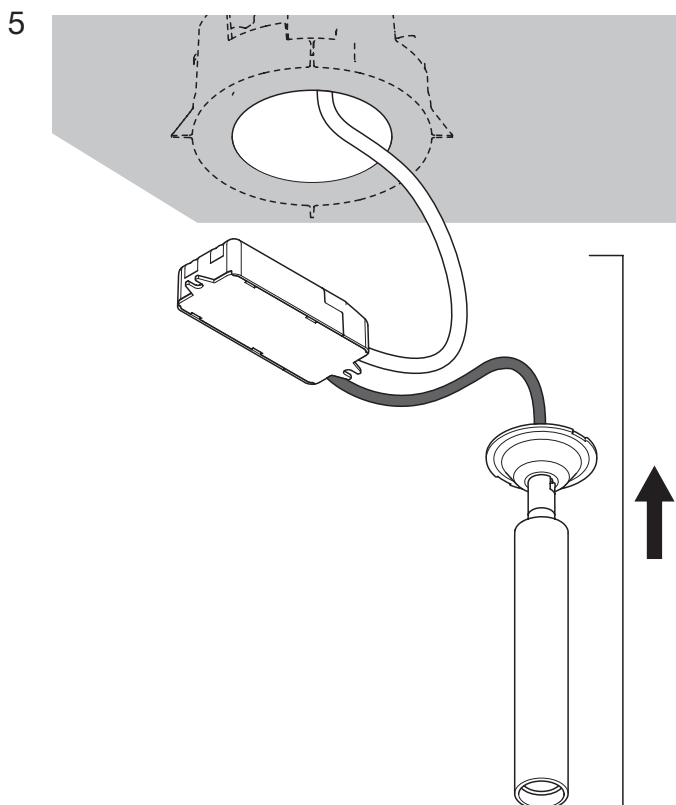
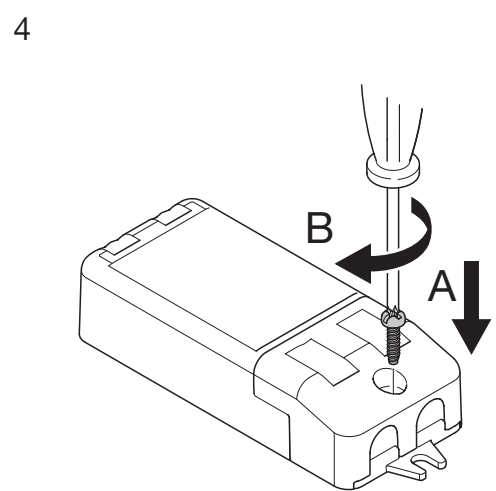
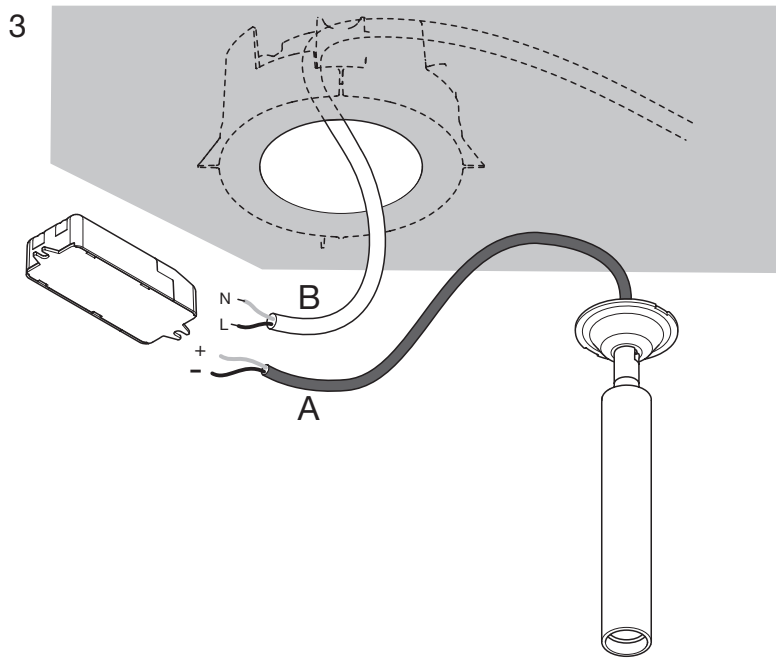
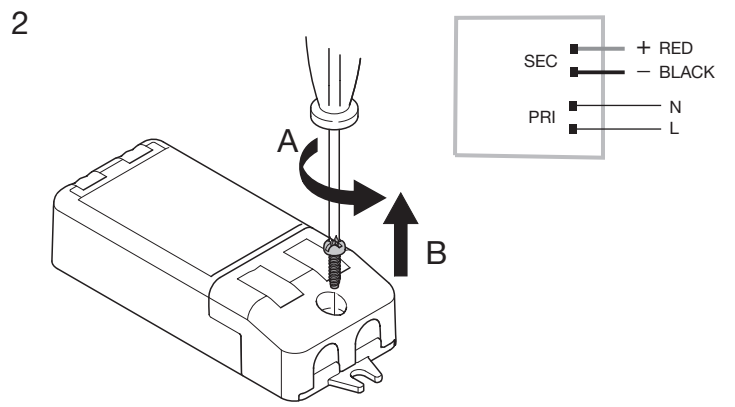
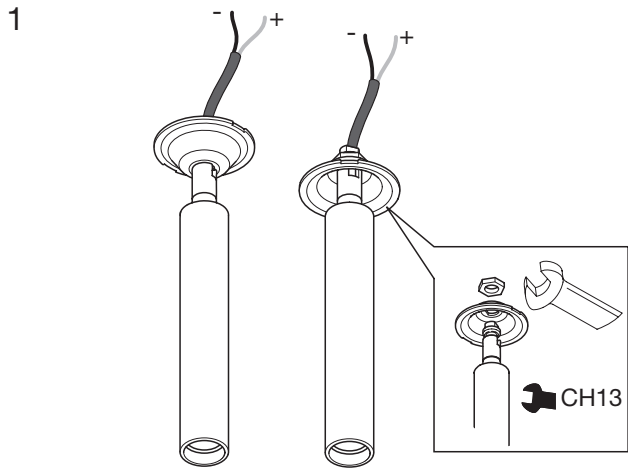

1

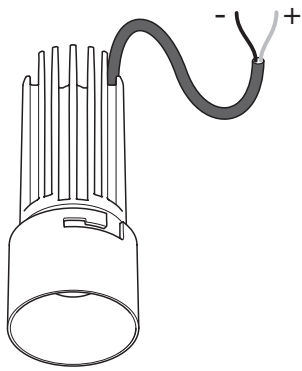

2

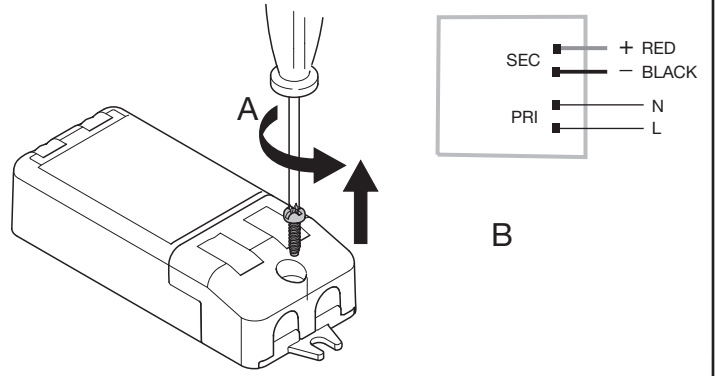

3

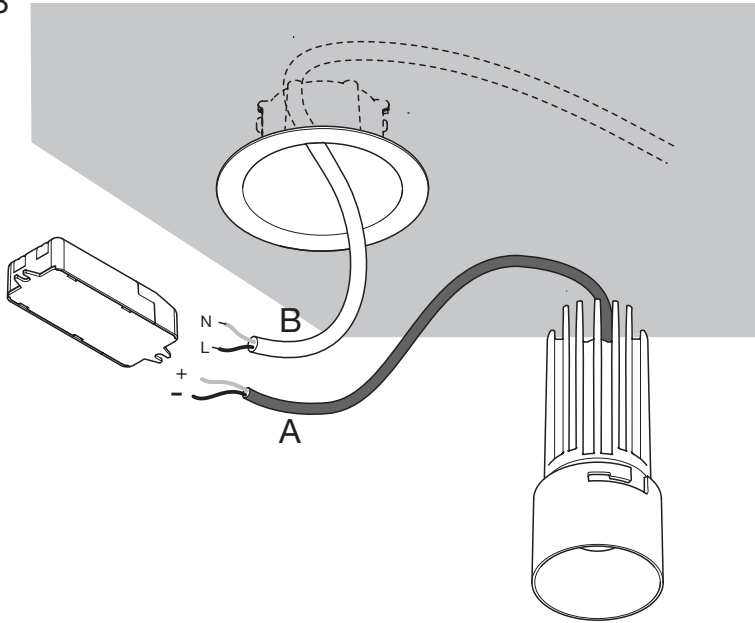

4

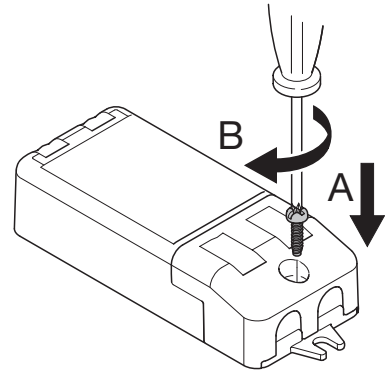

5

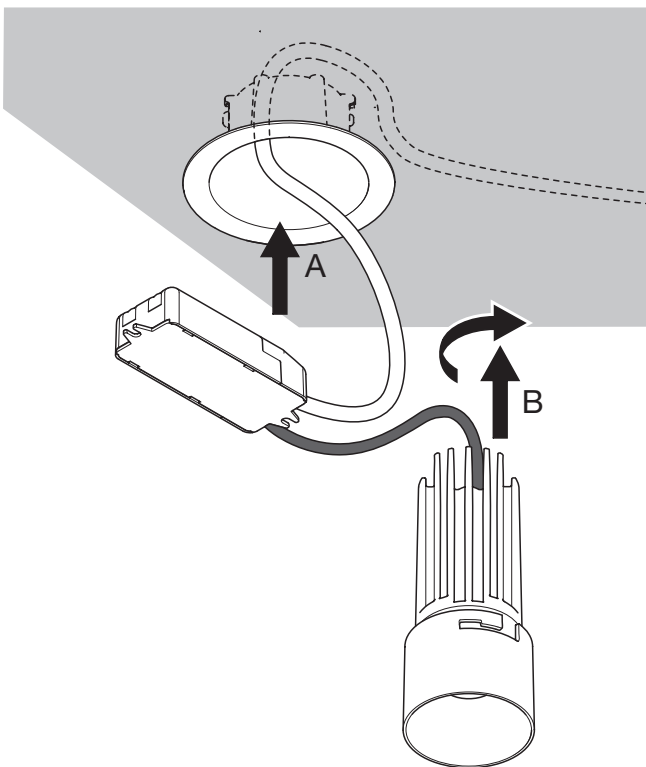

6

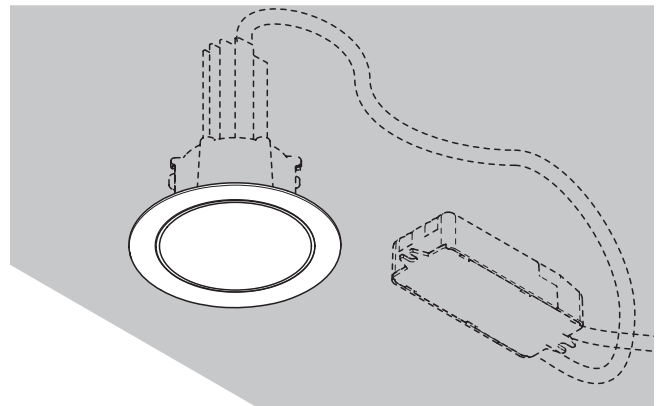

1

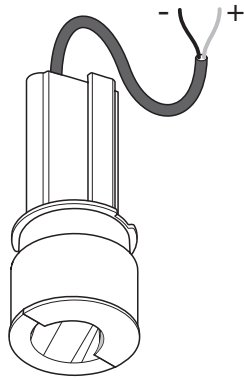

2

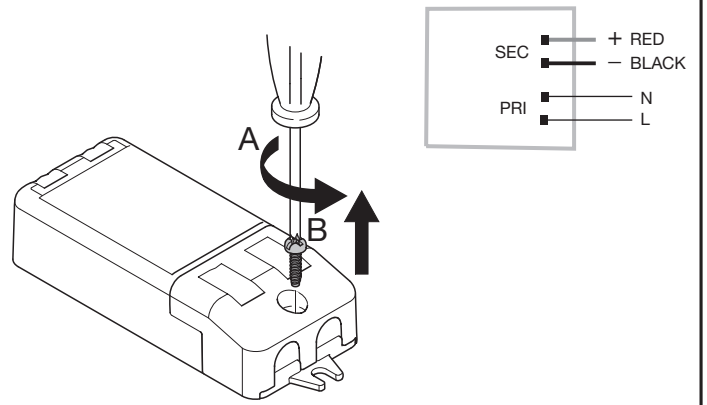

3

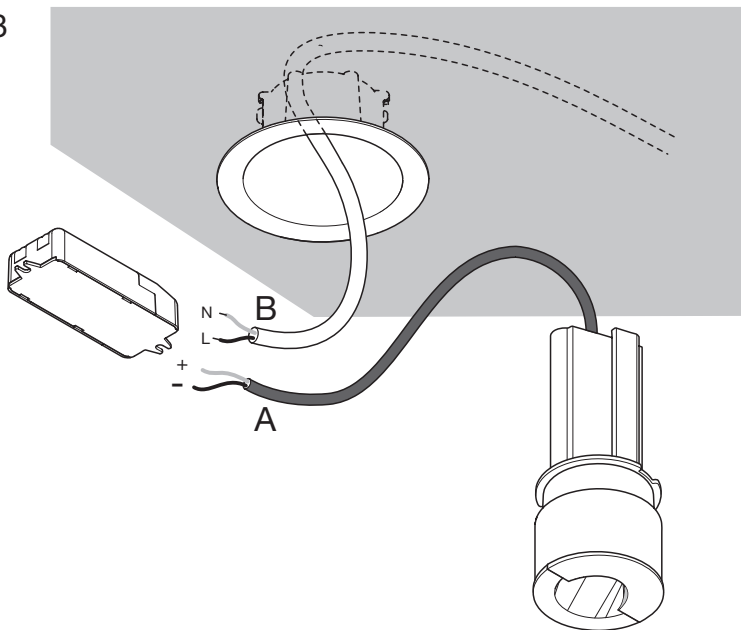

4

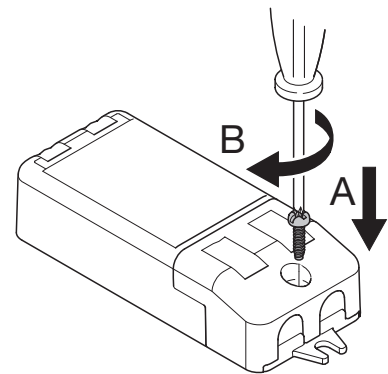

5

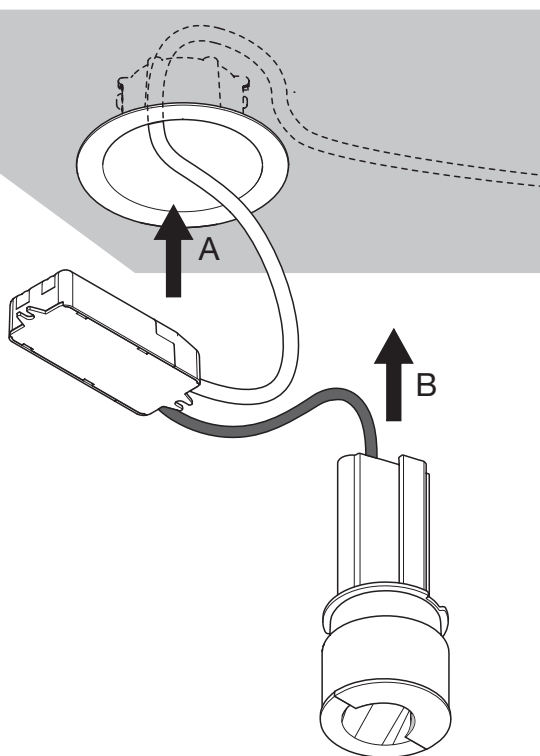

6

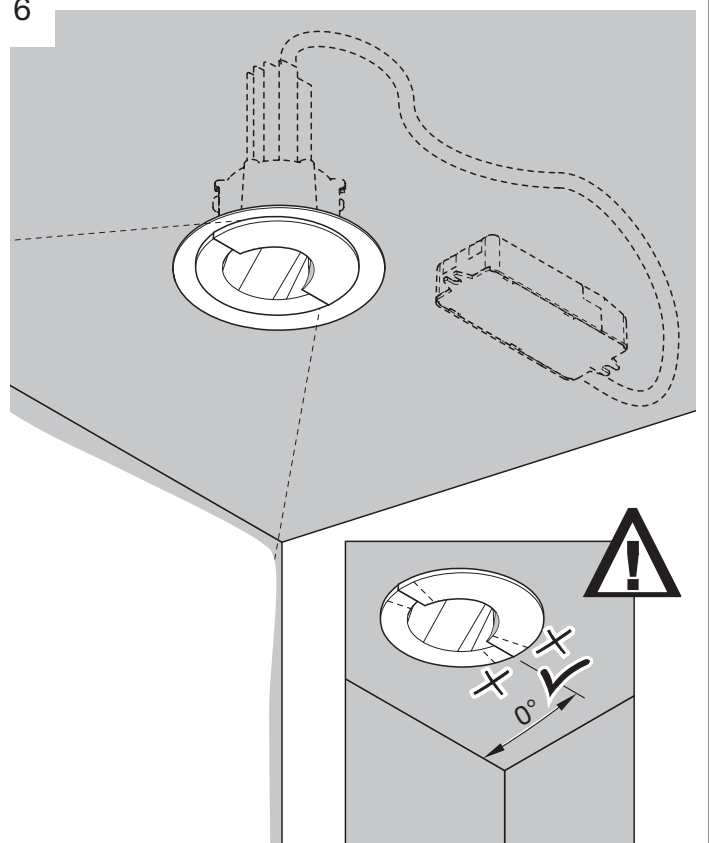



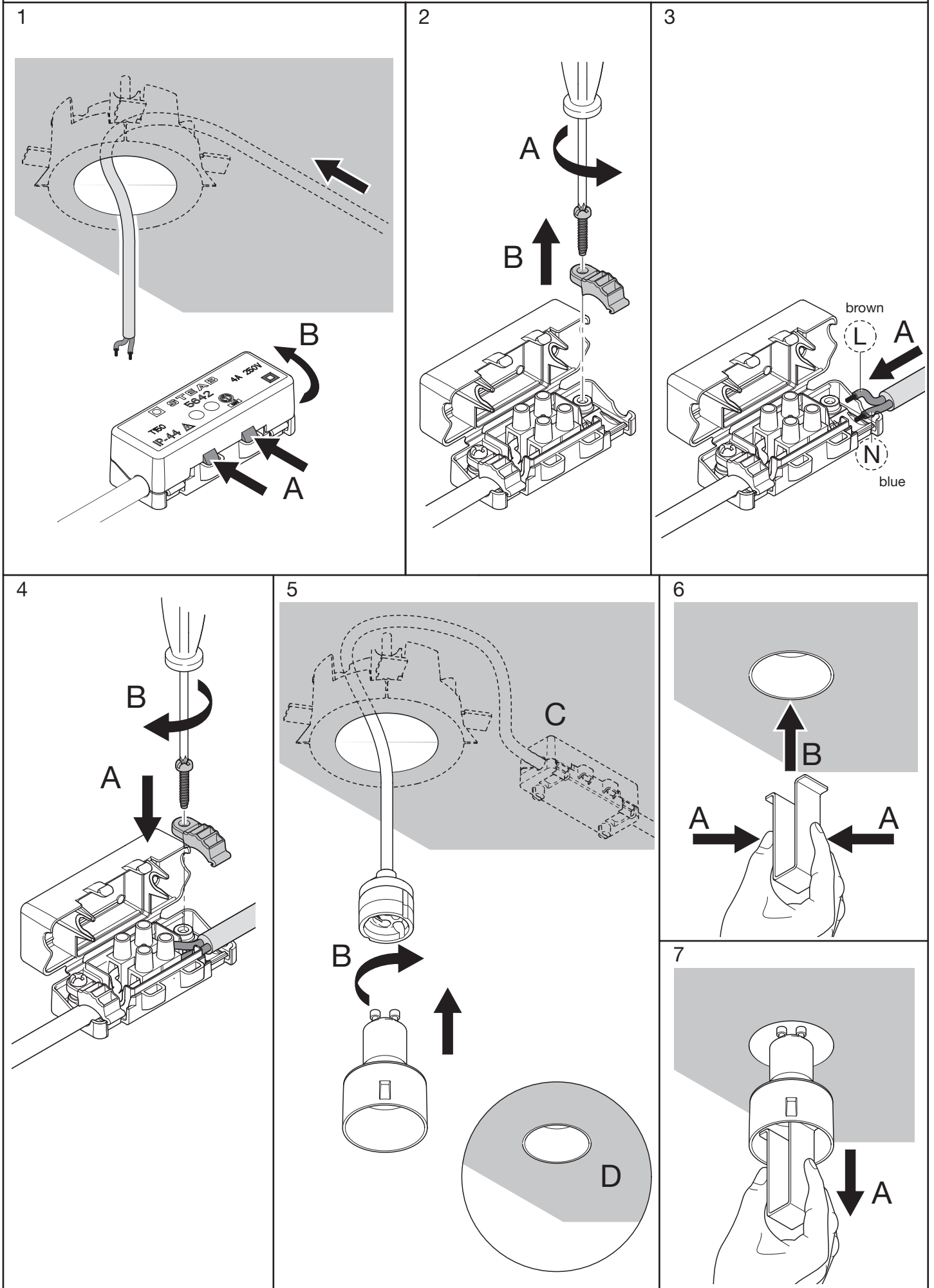

**Garanzia**

Tutti i prodotti Cini&Nils sono costruiti con materiali di prima qualità, sottoposti a severe procedure di collaudo e sono garantiti 2 anni da difetti di fabbricazione secondo la normativa vigente.

**Guarantee**

All Cini&Nils luminaries are produced with first-quality materials, undergo strict test procedure and are covered by a 2-year guarantee against production defects according to laws in force.

**Garantie**

Sämtliche Cini&Nils Produkte sind mit Materialien erstklassiger Qualität hergestellt, werden zu strengen Abnahmeprüfungen unterbreitet und haben zwei Jahre Garantie gegen Produktionsdefekte nach den bestehenden Gesetzen.

**Garantie**

Tous les produits Cini&Nils sont fabriqués avec des matériaux de première qualité, soumis à sévères procédures d'essai et sont garantis 2 ans, selon la normative en vigueur, contre défauts de fabrication.

**Garantía**

Todos los productos Cini&Nils están fabricados con materiales de primera calidad, sometidos a estrictos procedimientos de prueba y están cubiertos por una garantía de 2 años contra defectos de fabricación, según las normas vigentes.

**Tutela dell'ambiente**

 Onde tutelare l'ambiente, non buttate l'apparecchio tra i normali rifiuti al termine della sua vita utile, ma portatelo presso i punti di raccolta specifici per questi rifiuti previsti dalla normativa vigente.

**Protecting the environment**

 To protect our environment, please do not dispose of this luminaire together with ordinary refuse when its working life comes to an end. Provision has been made by law for special collection points for refuse of this kind: please take it to one of these. Thank you.

**Umweltschutzhinweis**

 Bitte geben Sie diese Leuchte am Ende ihrer Nutzungsdauer nicht in den Hausmüll, sondern liefern Sie bei einer gemäß den einschlägigen Bestimmungen geeigneten Recycling-Einrichtung ab.

**Protection de l'environnement**

 Afin de protéger l'environnement, ne jetez pas l'appareil dans les ordures normales à la fin de sa durée de vie utile; portez-le dans un des centres de collecte spécifiques prévus pour ces déchets par la réglementation en vigueur.

**Tutela del ambiente**

 Con el fin de tutelar el ambiente, no tire el aparato entre los desechos normales al final de su vida útil. Llévelo a un centro de recogida específico para este tipo de desechos previsto por las normativas vigentes.

**Copyright © Cini&Nils Milano, Italia.**

I testi e le immagini sono protetti da diritto d'autore. Riproduzione non autorizzata.

**Copyright © by Cini&Nils Milan, Italy.**

These texts and images are covered by copyright. All unauthorized reproduction is prohibited.

**Copyright © Cini&Nils Mailand, Italien.**

Alle Texte und Abbildungen sind urheberrechtlich geschützt. Keine unerlaubte Wiedergabe.

**Copyright © Cini&Nils Milan, Italia.**

Les textes et les images sont protégés par des droits d'auteur. Reproduction interdite.

**Copyright © Cini&Nils Milán, Italia.**

Los textos y las imágenes están protegidos por el derecho de autor. Reproducción no autorizada.



CINI&NILS

via Pizzigoni 3 - 24060 Villongo (BG)  
T +39 02 3343071  
info@cinienils.com www.cinienils.com